

Garmin International, Inc.
1200 E. 151st Street
Olathe, Kansas 66062 U.S.A.

FAA APPROVED

AIRPLANE FLIGHT MANUAL SUPPLEMENT
or
SUPPLEMENTAL AIRPLANE FLIGHT MANUAL
for the
Garmin GTX 33X and GTX 3X5 Transponders with ADS-B
as installed in

Piper PA 24-250
Make and Model Airplane

Registration Number: N5799P Serial Number: 2A-879

This document serves as an FAA Approved Airplane Flight Manual Supplement or Supplemental Airplane Flight Manual when the GTX 33X or GTX 3X5 with ADS-B is installed in accordance with Supplemental Type Certificate SA01714W1. This document must be incorporated into the FAA Approved Airplane Flight Manual or provided as an FAA Approved Supplemental Airplane Flight Manual.

The information contained herein supplements the FAA approved Airplane Flight Manual. For limitations, procedures, loading and performance information not contained in this document, refer to the FAA approved Airplane Flight Manual, markings, or placards.

FAA Approved By: JR Brownell

JR Brownell
ODA STC Unit Administrator
Garmin International, Inc.
ODA-240087-CE

Date: 9-9-2019

LOG OF REVISIONS				
Revision Number	Page		Description	FAA Approved
	Date	Number		
1	05/01/2013	All	Complete Supplement	<u><i>Robert Murray</i></u> Robert Murray ODA STC Unit Administrator Garmin International, Inc. ODA-240087-CE Date: <u><i>05/01/2013</i></u>
2	03/08/2016	All	New supplement format with GTX 3X5 added.	<u><i>Michael Warren</i></u> Michael Warren ODA STC Unit Administrator Garmin International, Inc. ODA-240087-CE Date: <u><i>03/08/2016</i></u>
3	12/07/2017	All	Updated SW versions and removed section 3.2.3. Updated section 2.2 Corrected PED FAR reference and additional minor corrections.	<u><i>Erik Frisk</i></u> Erik Frisk ODA STC Unit Administrator Garmin International, Inc. ODA-240087-CE Date: <u><i>12/21/2017</i></u>
4	09/09/2019	4, 6, 7, 9, 11, 13, 14, 18	Added GTX diversity units, updated SW versions, expanded allowed remote control panels, and incorporated other minor changes	See cover page 1

Table of Contents

SECTION	PAGE
Section 1. GENERAL	4
1.1 GTX 33X	4
1.2 GTX 3X5	6
1.3 Capabilities	8
1.4 Installation Configuration	9
1.5 Definitions	12
Section 2. LIMITATIONS	13
2.1 Minimum Equipment	13
2.2 ADS-B Out	13
2.3 TIS Traffic Display with User Navigation Angle	13
2.4 Applicable System Software	14
2.5 Pressure Altitude Broadcast Inhibit (PABI)	14
2.6 Datalinked Weather Display (GTX 345 Only)	14
2.7 Portable Electronic Devices	14
Section 3. EMERGENCY PROCEDURES	15
3.1 Emergency Procedures	15
3.2 Abnormal Procedures	15
Section 4. NORMAL PROCEDURES	16
4.1 Unit Power On	16
4.2 Before Takeoff	17
Section 5. PERFORMANCE	17
Section 6. WEIGHT AND BALANCE	17
Section 7. SYSTEM DESCRIPTION	18
7.1 GTX TIS Behavior	18
7.2 GTX 345R and G950/1000 No Bearing Traffic Alerts	18

Section 1. GENERAL

1.1 GTX 33X

The Garmin GTX 33X family consists of the GTX 330 ES and GTX 33 ES (Non-Diversity Mode S Transponders) and the GTX 330D ES and GTX 33D ES (Diversity Mode S Transponders). The ES option of any of the transponders provides ADS-B extended squitter functionality.

All Garmin GTX 33X transponders are a radio transmitter/receiver that operates on radar frequencies, receiving ground radar or TCAS interrogations at 1030 MHz and transmitting a coded response of pulses to ground-based radar on a frequency of 1090 MHz. Each unit is equipped with IDENT capability to initiate the SPI (special position identification) pulse for 18 seconds and will reply to ATCRBS Mode A, Mode C and Mode S All-Call interrogation. Interfaces to the GTX 33X are shown in the following block diagrams.

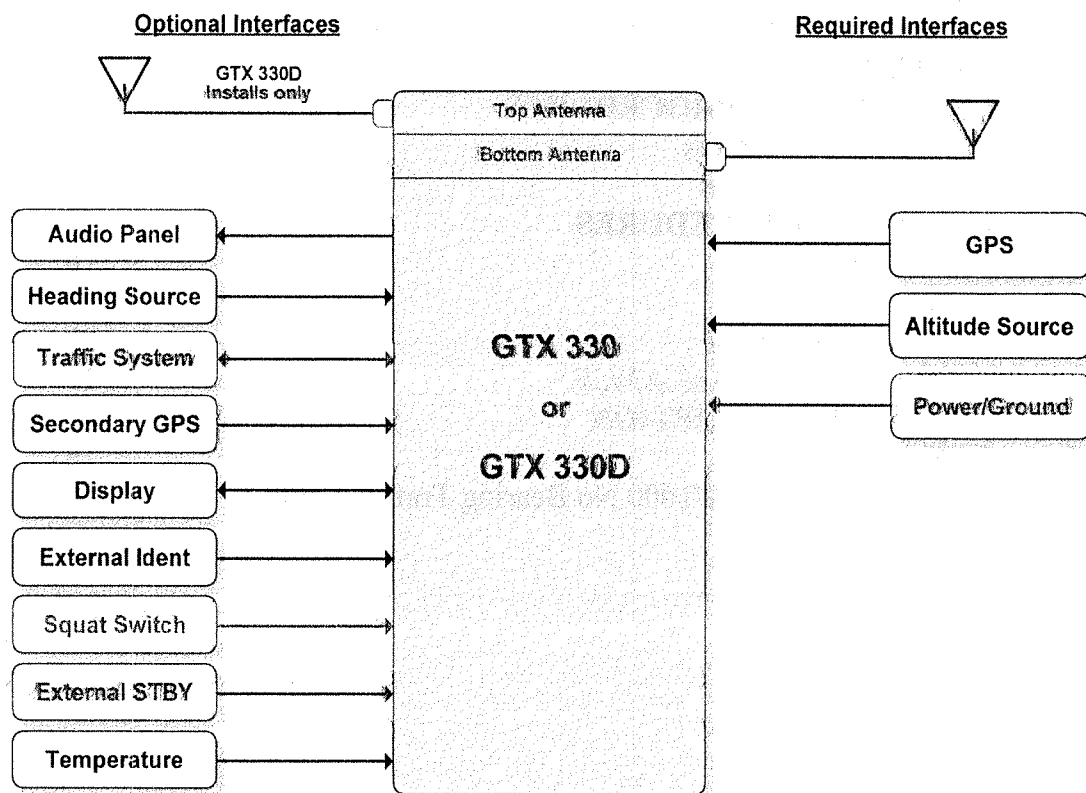

Figure 1 – GTX 330 or GTX 330D Interface Summary

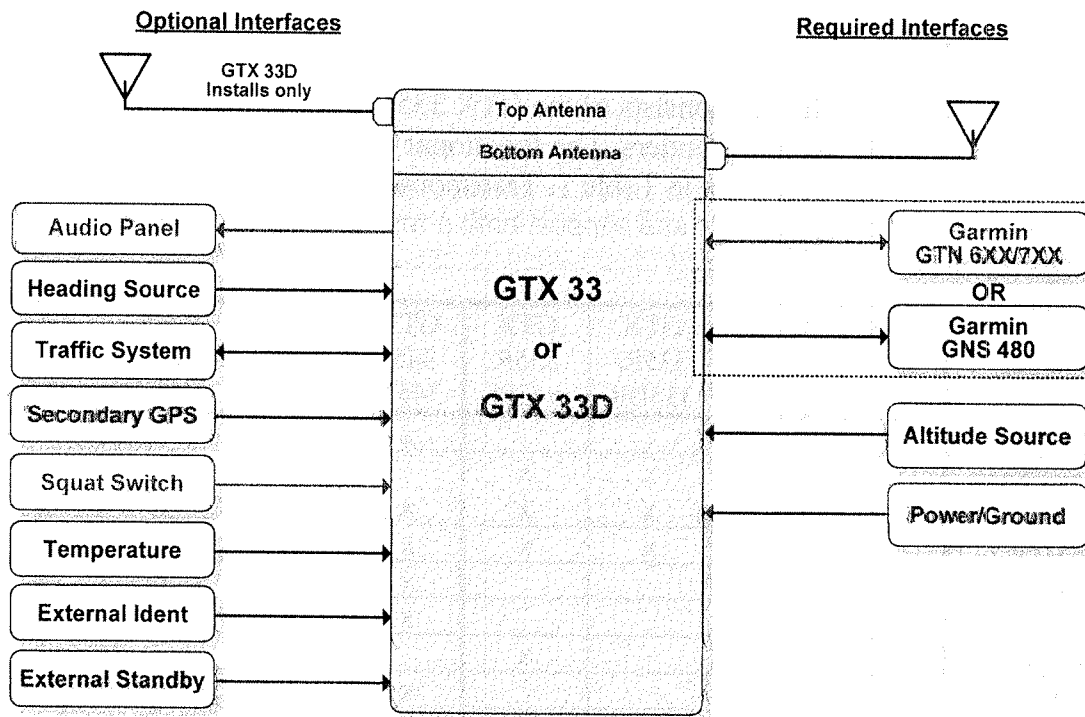

Figure 2 – GTX 33 or GTX 33D Interface Summary

The GTX 33X performs the following functions:

- Transmission of ADS-B out data on 1090 extended squitter (1090 MHz)
 - Integration of data from internal and external sources to transmit the following data per 14 CFR 91.227:
 - GPS Position, Altitude, and Position Integrity
 - Ground Track and/or Heading, Ground Speed, and Velocity Integrity
 - Air Ground Status
 - Flight ID, Call Sign, ICAO Registration Number
 - Capability and Status Information
 - Transponder Squawk Codes between 0000-7777.
 - Emergency Status
 - IDENT - initiates SPI (special position identification) pulse for 18 seconds
 - Pressure Altitude Broadcast Inhibit
- Reception of TIS-A traffic data from a ground station
- Provides TIS-A traffic alerting to the pilot via interfaced display and audio output

1.2 GTX 3X5

The Garmin GTX 3X5 family consists of the GTX 335, 335D, 335R, 335DR, 345, 345D, 345R, and 345DR transponders. The functional differences between each of these transponders are described in Table 1. Transponder models with a “D” designation are diversity capable and support both a top fuselage and bottom fuselage antenna.

Function	GTX 335/335D	GTX 335 w/GPS	GTX 335R/335DR	GTX 335R w/GPS	GTX 345/345D	GTX 345 w/GPS	GTX 345R/345DR	GTX 345R w/GPS
Panel mount	x	x			x	x		
Remote mount			x	x			x	x
Mode S	x	x	x	x	x	x	x	x
ADS-B (out)	x	x	x	x	x	x	x	x
ADS-B Traffic					x	x	x	x
FIS-B					x	x	x	x
Internal GPS		x		x		x		x
Bluetooth					x	x	x	x
Optional Garmin Altitude Encoder	x	x	x	x	x	x	x	x

Table 1 – GTX 3X5 Unit Configurations

Interfaces to the GTX 3X5 are shown in Figure 3.

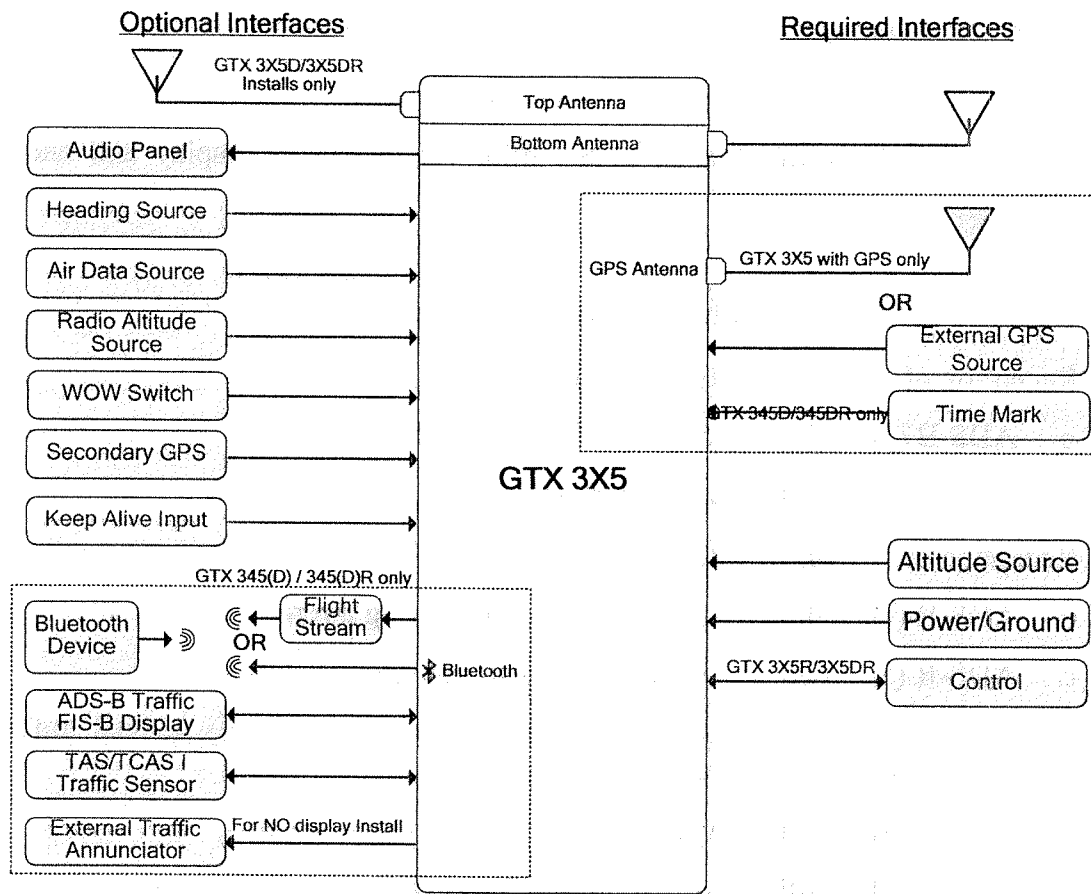

Figure 3 – GTX 3X5 Interface Summary

The GTX 3X5 performs the following functions:

- Transmission of ADS-B out data on 1090 extended squitter (1090 MHz)
 - Integration of data from internal and external sources to transmit the following data per 14 CFR 91.227:
 - GPS Position, Altitude, and Position Integrity
 - Ground Track and/or Heading, Ground Speed, and Velocity Integrity
 - Air Ground Status
 - Flight ID, Call Sign, ICAO Registration Number
 - Capability and Status Information
 - Transponder Squawk Codes between 0000-7777.
 - Emergency Status
 - IDENT - initiates SPI (special position identification) pulse for 18 seconds
 - Pressure Altitude Broadcast Inhibit

The GTX 335 performs the following additional functions:

- Reception of TIS-A traffic data from a ground station
- Provide TIS-A traffic alerting to the pilot via interfaced display and audio output.

The GTX 345 performs the following additional functions:

- Reception of ADS-B In data on 1090 MHz
 - ADS-B (Data directly from another transmitting aircraft)
 - ADS-R (Rebroadcast of ADS-B data from a ground station)
- Reception of ADS-B In data on UAT (978 MHz)
 - ADS-B (Data directly from another transmitting aircraft)
 - ADS-R (Rebroadcast of ADS-B data from a ground station)
 - TIS-B (Broadcast of secondary surveillance radar) (SSR) derived traffic information from a ground station.
 - FIS-B (Broadcast of aviation data from a ground station)
- Provide ADS-B traffic information and alerting to the pilot via an interfaced display
 - Correlation and consolidation of traffic data from multiple traffic sources
 - Aural and visual traffic alerting
- Provide FIS-B data to the pilot via an interfaced display
 - Graphical and textual weather products
 - NEXRAD
 - PIREPs
 - AIRMET/SIGMETs
 - METARs
 - TAFs
 - Winds Aloft
 - Aviation Data
 - TFRs
 - NOTAMs

1.3 Capabilities

The Garmin GTX 33X and GTX 3X5 as installed in this aircraft have been shown to meet the equipment requirements of 14 CFR § 91.227 when operating in accordance with sections 2.1 and 2.2 of this supplement.

1.4 Installation Configuration

This aircraft is equipped with a GTX 33X and/or GTX 3X5 with the following interfaces/ features:

Equipment Installed:

<u>Transponder #1</u>	<u>Transponder #2 (if installed)</u>
<input type="checkbox"/> GTX 330	<input type="checkbox"/> GTX 330
<input type="checkbox"/> GTX 330D	<input type="checkbox"/> GTX 330D
<input type="checkbox"/> GTX 33	<input type="checkbox"/> GTX 33
<input type="checkbox"/> GTX 33D	<input type="checkbox"/> GTX 33D
<input type="checkbox"/> GTX 335	<input type="checkbox"/> GTX 335
<input type="checkbox"/> GTX 335D	<input type="checkbox"/> GTX 335D
<input type="checkbox"/> GTX 335R	<input type="checkbox"/> GTX 335R
<input type="checkbox"/> GTX 335DR	<input type="checkbox"/> GTX 335DR
<input checked="" type="checkbox"/> GTX 345	<input type="checkbox"/> GTX 345
<input type="checkbox"/> GTX 345D	<input type="checkbox"/> GTX 345D
<input type="checkbox"/> GTX 345R	<input type="checkbox"/> GTX 345R
<input type="checkbox"/> GTX 345DR	<input type="checkbox"/> GTX 345DR

Interfaced GPS/SBAS Position Source(s):

<u>GPS #1</u>	<u>GPS #2 (if installed)</u>
<input type="checkbox"/> Internal	<input type="checkbox"/> Internal
<input type="checkbox"/> GTN 6XX/7XX Series	<input type="checkbox"/> GTN 6XX/7XX Series
<input checked="" type="checkbox"/> GNS 400W/500W Series	<input type="checkbox"/> GNS 400W/500W Series
<input type="checkbox"/> GNS 480	<input type="checkbox"/> GNS 480
<input type="checkbox"/> GIA 63W	<input type="checkbox"/> GIA 63W
<input type="checkbox"/> GDL 88 (GTX 330 only)	<input type="checkbox"/> GDL 88 (GTX 330 only)

Interfaced Pressure Altitude Source:

Pressure Altitude Source #1

ANALOG ENCODER

Garmin Altitude Encoder

Pressure Altitude Source #2 (if installed)

Garmin Altitude Encoder

Interfaced Remote Control Display (Required for remotely mounted GTX variants):

Transponder #1 Remote Control Display

- GTN 6XX/7XX
- GNS 480
- G950/1000 Display
- Gables 7534 Controller
- Gables 7614 Controller
- CTL-92 Controller
- CTL-92E Controller

Transponder #2 Remote Control Display (if installed)

- GTN 6XX/7XX
- GNS 480
- G950/1000 Display
- Gables 7534 Controller
- Gables 7614 Controller
- CTL-92 Controller
- CTL-92E Controller

Interfaced Active Traffic System:

- None
- TCAD
- TAS/TCAS

NOTE

If the system includes all of the following components:

- GTX 345R or GTX 345DR,
- G950/1000 Display, and
- TCAD or TAS/TCAS

Then the aircraft is no longer equipped with a TSO compliant active TCAD, TAS or TCAS system. Any operational requirement to be equipped with such system is no longer met.

1.5 Definitions

The following terminology is used within this document:

ADS-B: Automatic Dependent Surveillance-Broadcast

AFM: Airplane Flight Manual

AFMS: Airplane Flight Manual Supplement

ATCRBS: Air Traffic Control Radar Beacon System

CFR: Code of Federal Regulations

ES: Extended Squitter

GNSS: Global Navigation Satellite System

GNS: Garmin Navigation System

GPS: Global Positioning System

GTX: Garmin Transponder

GTN: Garmin Touchscreen Navigator

ICAO: International Civil Aviation Organization

LRU: Line Replaceable Unit

PABI: Pressure Altitude Broadcast Inhibit

POH: Pilot Operating Handbook

SBAS: Satellite-Based Augmentation System

SW: Software

TCAS: Traffic Collision Avoidance System

TIS: Traffic Information Service

TX: Transmit

Section 2. LIMITATIONS

2.1 Minimum Equipment

The GTX 33X and GTX 3X5 must have the following system interfaces fully functional in order to be compliant with the requirements for 14 CFR 91.227 ADS-B Out operations:

Interfaced Equipment	Number Installed	Number Required
Uncorrected Pressure Altitude Source	1	1
GPS SBAS Position Source	1 or more	1
Remote Control Display (for remotely mounted transponders)	1 or more	1

Table 2 – Required Equipment

2.2 ADS-B Out

The GTX 33X and GTX 3X5 only comply with 14 CFR 91.227 for ADS-B Out when all required functions are operational. When the system is not operational, ADS-B Out transmit failure messages will be present on the remote control display interface, or the GTX 330 or GTX 3X5 panel display. If a Gables 7534 controller or Collins CTL-92/92E controller is being used the ADS-B equipment failure condition will be annunciated on the Gables or Collins display “Transponder Fail” while the ADS-B Out Position failure will be annunciated by the remotely installed “ADS-B POSN FAIL” Annunciator.

2.3 TIS Traffic Display with User Navigation Angle

Display of TIS traffic from a GTX 33/330 or GTX 335 is not permitted with an interfacing display configured for a navigation angle of “user”.

2.4 Applicable System Software

This AFMS/AFM is applicable to the software versions shown in Table 3.

The Main GTX software version is displayed on the splash screen during start up for the GTX 330 and GTX 3X5 panel mounted units, and the External LRU or System page on the interfaced remote control display for remotely mounted GTX transponders.

Software Item	Software Version <i>(or later FAA Approved versions for this STC)</i>
GTX 33X Main SW Version	8.04
GTX 3X5 Main SW Version	2.54

Table 3 - Software Versions

2.5 Pressure Altitude Broadcast Inhibit (PABI)

Pressure Altitude Broadcast Inhibit shall only be enabled when requested by Air Traffic Control while operating within airspace requiring an ADS-B Out compliant transmitter. PABI is enabled by selecting the GTX to ON mode.

2.6 Datalinked Weather Display (GTX 345 Only)

Do not use datalink weather information for maneuvering in, near, or around areas of hazardous weather. Information provided by datalink weather products may not accurately depict current weather conditions.

Do not use the indicated datalink weather product age to determine the age of the weather information shown by the datalink weather product. Due to time delays inherent in gathering and processing weather data for datalink transmission, the weather information shown by the datalink weather product may be significantly older than the indicated weather product age.

Do not rely solely upon datalink services to provide Temporary Flight Restriction (TFR) or Notice to Airmen (NOTAM) information.

2.7 Portable Electronic Devices

This STC does not relieve the operator from complying with the requirements of 91.21 or any other operational regulation regarding portable electronic devices.

Section 3. EMERGENCY PROCEDURES

3.1 Emergency Procedures

No Change.

3.2 Abnormal Procedures

3.2.1 LOSS OF AIRCRAFT ELECTRICAL POWER GENERATION

XPDR Circuit Breaker..... **PULL**

Transponder and ADS-B Out functions will no longer be available.

NOTE

This guidance is supplementary to any guidance provided in the POH or AFM for the installed aircraft for loss of power generation.

3.2.2 LOSS OF GPS/SBAS POSITION DATA

When the GPS/SBAS receiver is inoperative or GPS position information is not available or invalid, the GTX will no longer be transmitting ADS-B Out data.

For GTX 330 installations:

NO ADSB annunciator illuminated:

Interfaced GPS position sources..... **VERIFY VALID POSITION**

For GTX 3X5 installations:

NO 1090ES TX annunciator illuminated:

Interfaced GPS position sources..... **VERIFY VALID POSITION**

For GTX 33 and GTX 3X5R installations:

Reference Display Device documentation for applicable annunciation:

Interfaced GPS position sources..... **VERIFY VALID POSITION**

Section 4. NORMAL PROCEDURES

The procedures described below are specific only to the panel mounted GTX 330 or GTX 3X5 transponders. Cockpit Reference Guides and Pilot Guides for interfaced remote control displays will provide additional operating information specific to the displays or other traffic systems.

ADS-B Out functionality resides within the GTX transponders thereby providing a single point of entry for Mode 3/A code, Flight ID, IDENT functionality and activating or deactivating emergency status for both transponder and ADS-B Out functions. Details on performing these procedures are located in the GTX 330/330D Pilot's Guide and GTX 3X5 Series Transponder Pilot's Guide.

4.1 Unit Power On

For GTX 330 installations:

GTX Mode..... **VERIFY ALT**
NO ADSB..... **CONSIDERED**

For GTX 3X5 installations:

GTX Mode..... **VERIFY ALT**
NO 1090ES TX **CONSIDERED**

NOTE

The NO ADS-B or NO 1090ES TX Annunciation (or associated display annunciations) may illuminate as the unit powers on and begins to receive input from external systems, to include the SBAS position source.

4.2 Before Takeoff

For GTX 330 installations:

ADS-B TX..... **VERIFY ON**
NO ADSB **EXTINGUISHED**

For GTX 3X5 installations:

1090ES TX CTL **VERIFY ON**
NO 1090ES TX **EXTINGUISHED**

NOTE

The ADS-B TX or 1090ES TX CTL must be turned on and the NO ADS-B or NO 1090ES TX Annunciation (or associated display annunciations) must be **EXTINGUISHED** for the system to meet the requirements specified in 14 CFR 91.227. This system must be operational in certain airspaces after January 1, 2020 as specified by 14 CFR 91.225.

Section 5. PERFORMANCE

No change.

Section 6. WEIGHT AND BALANCE

See current weight and balance data.

Section 7. SYSTEM DESCRIPTION

The Garmin GTX 330 and GTX 3X5 Pilot's Guides, part numbers, and revisions listed below contain additional information regarding GTX system description, control, and function.

<u>Title</u>	<u>Part Number</u>	<u>Revision</u>
GTX 330 Pilot's Guide	190-00207-00	Rev. G (or later)
GTX 3X5 Pilot's Guide	190-01499-00	Rev. A (or later)

Pilot's Guides for interfaced displays, part numbers and revisions listed below, provide additional operating information for the Garmin GTX 33 and GTX 3X5R.

<u>Title</u>	<u>Part Number</u>	<u>Revision</u>
Garmin GTN 725/750 Pilot's Guide	190-01007-03	Rev. E (or later)
Garmin GTN 625/635/650 Pilot's Guide	190-01004-03	Rev. E (or later)
GNS 480 Pilot's Guide	190-00502-00	Rev. D (or later)
GTX 3X5 Series Transponder G1000 Pilot's Guide	190-01499-01	Rev. A (or later)

7.1 GTX TIS Behavior

The TIS Standby/Operate controls for GTX 33/330 and GTX 335/335D units only function when the aircraft is airborne.

7.2 GTX 345R/345DR and G950/1000 No Bearing Traffic Alerts

No visual indication is provided for no bearing traffic alerts. Only an aural indication of the no bearing traffic alert is provided. If an aural alert for no bearing traffic has been previously issued, a "no bearing traffic clear" aural indication will be provided once all traffic alerts are resolved.

All aural alerts are inhibited below 500' AGL, therefore a "no bearing traffic clear" aural may not be heard in a landing or touch and go flight scenario.

4 INSTRUCTIONS FOR CONTINUED AIRWORTHINESS

4.1	Applicability	4-2
4.2	Airworthiness Limitations	4-2
4.3	Servicing Information	4-3
4.3.1	On Condition Servicing	4-3
4.3.2	Special Tools	4-3
4.4	Maintenance Intervals	4-4
4.5	Visual Inspection	4-5
4.6	Electrical Bonding Test	4-7
4.7	Additional Instructions	4-7

This section provides Instructions for Continued Airworthiness for the GTX 33X and GTX 3X5 with ADS-B installation. This section satisfies the requirements for continued airworthiness as defined by 14 CFR Part 23.1529 and Part 23 appendix G. Information in this section is required to maintain the continued airworthiness of the GTX 33X and GTX 3X5 as installed under this AML STC.

4.1 Applicability

This document applies to all aircraft equipped with GTX 33X and GTX 3X5 units with ADS-B per STC SA01714W1.

Modification of an aircraft by this STC obligates the aircraft operator to include the maintenance information provided by this document in the operator's Aircraft Maintenance Manual and the operator's Aircraft Scheduled Maintenance Program.

4.2 Airworthiness Limitations

There are no new (or additional) airworthiness limitations associated with this equipment and/or installation..

The Airworthiness Limitations section is FAA approved and specifies maintenance required under §§43.16 and 91.403 of the Federal Aviation Regulations unless an alternative program has been FAA approved.

FAA APPROVED



JR Brownell
ODA STC Unit Administrator
ODA-240087-CE

9-9-2019

Date

4.3 Servicing Information

GTX 33X and GTX 3X5 LRU maintenance is “on-condition” only. Component-level overhaul is not required for the GTX 33X and GTX 3X5 with ADS-B installation.

4.3.1 On Condition Servicing

On Condition replacement and/or servicing should occur when an item exhibits conditions, symptoms, and/or abnormalities as defined in Section 5 of this manual. Replacement and/or servicing should be made only after the technician troubleshoots the system by using the guidance in this manual along with common avionics maintenance practices.

4.3.2 Special Tools

The following tools are needed to perform maintenance tasks.

- Calibrated milliohm meter with an accuracy of ± 0.1 milliohm or better
- Calibrated transponder ramp tester
- Calibrated Pitot/static ramp tester
- GTX 3X5 Install Tool (remote units only)
- 50 Ω 5 watt antenna load

4.4 Maintenance Intervals

Table 4-1 shows systems and components, installed by this STC, which must undergo tests or checks at specific intervals. The inspections based on calendar elapsed time have specifically stated intervals.



NOTE

The maintenance intervals listed in the table below must be adhered to for each installed GTX.

Table 4-1 Maintenance Intervals

Item	Description/Procedure	Section	Interval
Equipment Removal and Reinstallation	Removal and reinstallation of GTX LRUs.	6	On Condition
Cleaning	The GTX 330 and GTX 335/335D/345/345D display and bezel may be cleaned periodically. Cleaning is accomplished using a soft cotton cloth dampened with clean water. DO NOT use any chemical cleaning agents. Avoid scratching the surface of the display.	N/A	On Condition
Antenna Visual Inspection	Removal and replacement.	4.5	On Condition
Lightning Strike - Actual or Suspected	Inspect the coaxial cable connections, GTX bonding hardware (including bonding straps and tape), antenna, and surrounding areas.	4.5	On Condition
	The GTX 33/330 and GTX 3X5 receiver sensitivity must be tested and shown to comply with Title 14 CFR Part 43 Appendix F.	4.	On Condition
Testing	The GTX 33/330 and GTX 3X5 must be tested and shown to comply with Title 14 CFR Part 91.227.	8.7	Replacement of GPS Position source(s).
Equipment Visual Inspection	A visual inspection of the equipment installed by this STC must be performed.	4.5	12 Calendar Months
Testing	The GTX 33/330 and GTX 3X5 must be tested and shown to comply with Title 14 CFR Part 91.411, 91.413, and Part 43 Appendix E and F.	4.	Refer to Title 14 CFR Part 91.411, 91.413, and Part 43 Appendix E and F.
Electrical Bonding Test	An electrical bonding test must be performed on equipment installed by this STC.	4.6	10 Years or 2000 hours

4.5 Visual Inspection

Perform a visual inspection in accordance with requirements in this section. Check for corrosion, damage, or other defects for each of the installed items. Replace any damaged parts as required. Inspection may require the temporary removal of a unit or units to gain access to connectors. Follow guidance in Section 6 for equipment removal and replacement. Refer to Appendix A of this manual for equipment locations. Refer to the specific Aircraft Maintenance Manual for instructions on removing any access panels.

GTX 330/330D/335/335D/345/345D Visual Inspection

During normal aircraft inspections not to exceed 12 calendar month intervals, conduct a visual inspection of the GTX 330/330D/335/335D/345/345D installation in the following locations.

Instrument Panel

1. Inspect all GTX 330/330D/335/335D/345/345D keys for legibility of labels and markings.
2. Inspect GTX 330/330D/335/335D/345/345D units for security of attachment.
3. Inspect mounting rack and hardware for integrity.
 - a. Verify the racks, fasteners, and support structure are in good condition and securely fastened.
 - b. Inspect for signs of corrosion.
 - c. For composite aircraft, inspect any aluminum foil tape used to ground the GTX and verify that it is not torn, damaged, or showing signs of corrosion. If any of these occur then the tape must be replaced. Refer to Appendix B for details.
4. Inspect any bonding straps for corrosion, loose connections, or signs of damage. Refer to Appendix B for details.
5. Inspect the condition of the wiring harnesses and coaxial cables.
 - a. Inspect all instrument panel wiring and coax for chafing, damage, proper routing of wire bundles and security of attachment in accordance with AC 43.13-1B, chapter 11, section 8, paragraph 11-96. Pay particular attention to possible areas of chafing.
 - b. Verify that the harness shows no signs of cracking, chafing, abrasion, melting, or any other form of damage.
 - c. Inspect the GTX 330/330D/335/335D/345/345D connectors for corrosion or other defects. Check the integrity of the shield block ground attachments to the harness connector assembly as well as the integrity of the individual shields and their attachment.

GTX 33/33D/335R/335DR/345R/345DR Visual Inspection

During normal aircraft inspections not to exceed 12 calendar month intervals, conduct a visual inspection of the GTX 33/33D/335R/335DR/345R/345DR installation in the following locations.

Remote Mount Rack

1. Inspect GTX 33/33D/335R/335DR/345R/345DR units for security of attachment.
2. Inspect mounting rack and hardware for integrity.
 - a. Verify the racks, fasteners, and support structure are in good condition and are securely fastened.
 - b. Inspect for signs of corrosion.
 - c. For composite aircraft, inspect any aluminum foil tape used to ground the GTX and verify that it is not torn, damaged, or showing signs of corrosion. If any of these occur then the tape must be replaced. Refer to Appendix B for details.
3. Inspect any bonding straps for corrosion, loose connections, or signs of damage. Refer to Appendix B for details.
4. Inspect the condition of the wiring harnesses and coaxial cables.
 - a. Verify that all wiring and cables are securely fastened.
 - b. Verify that the harness shows no signs of cracking, chaffing, abrasion, melting, or any other form of damage.
 - c. Inspect the GTX 33/33D/335R/335DR/345R/345DR connectors for corrosion or other defects. Check the integrity of the shield block ground attachments to the harness connector assembly as well as the integrity of the individual shields and their attachment.

Antenna Visual Inspection

During normal aircraft inspections not to exceed 12 calendar month intervals, conduct a visual inspection of the transponder antennas for the following.

1. Erosion, cracks, dents, or broken antenna. If these conditions are present, antenna must be replaced. Refer to antenna manufacturer's replacement instructions for details.
2. If the attachment is not secure, re-work the installation and complete electrical bonding test specified in Section 4.6.
3. Condition of base seals. In the event the antenna seal shows sign of damage or decomposition, re-seal and complete the electrical bonding test specified in Section 4.6.

Post Lightning Strike Inspection

A post lightning strike inspection must be performed for a suspected or actual lightning strike to antennas or any temperature sensor connected to the GTX unit. Inspect antenna or sensor and surrounding installation to verify that structural damage has not occurred around the areas where lightning may have attached. If there is visible sign of damage to the antenna or sensor, then it should be replaced.

Inspect the antenna coax connection to GTX unit, grounding hardware, bonding straps or tape, and surrounding areas of the remotely mounted GTX to verify damage has not occurred. Repair any damaged areas and components, then complete the electrical bonding test specified in Section 4.6.

4.6 Electrical Bonding Test

1. Disconnect the antenna coaxial cable from the GTX 33X or GTX 3X5.
2. Disconnect all connectors from the GTX 33X or GTX 3X5.
3. Measure the DC resistance between each of the following test points and the aircraft ground reference as defined in Table B-1 and verify the resistance is less than or equal to the appropriate periodic test resistance value.
 - Top metal case of GTX 330/330D/335/335D/345/345D #1 (if installed)
 - Top metal case of GTX 330/330D/335/335D/345/345D #2 (if installed)
 - GTX 33/33D/335R/335DR/345R/345DR #1 chassis (if installed)
 - GTX 33/33D/335R/335DR/345R/345DR #2 chassis (if installed)
4. If the resistance is more than the periodic test resistance value in Table B-1, the bond must be improved enough to meet the reconditioned resistance value.

4.7 Additional Instructions

Electrical load information for the GTX is provided in Section 2.6.

